

THE INFORMATION CONTAINED IN THIS DRAWING IS THE SOLE PROPERTY OF POWER LIFT ANY REPRODUCTION IN PART OR WHOLE WITHOUT THE WRITTEN PERMISSION OF POWER LIFT IS PROHIBITED

REV.	DESCRIPTION	DATE	APPROVED
A	INITIAL RELEASE	4/1/2024	MK
B	BAR UPDATED FROM DOUBLE TO SINGLE PIN DESIGN	6/26/2024	MK

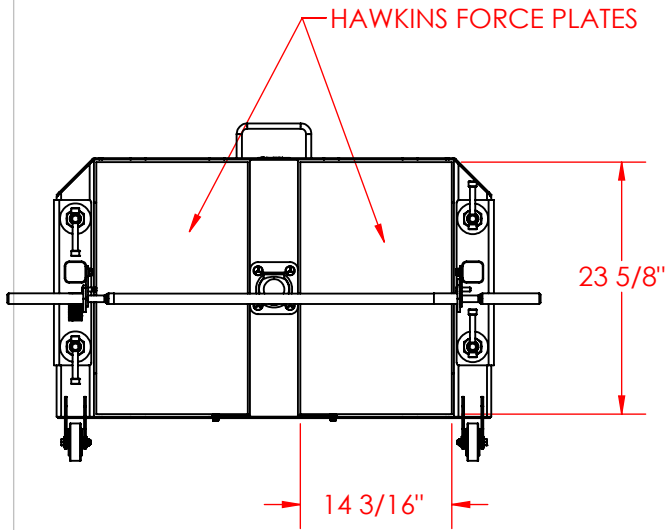

PLATED LASER CUT NUMBERS & NOTCHES

Ø 1" KNURLED ISOMETRIC BAR

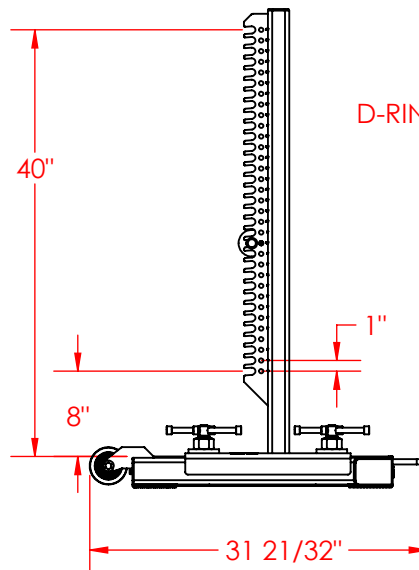
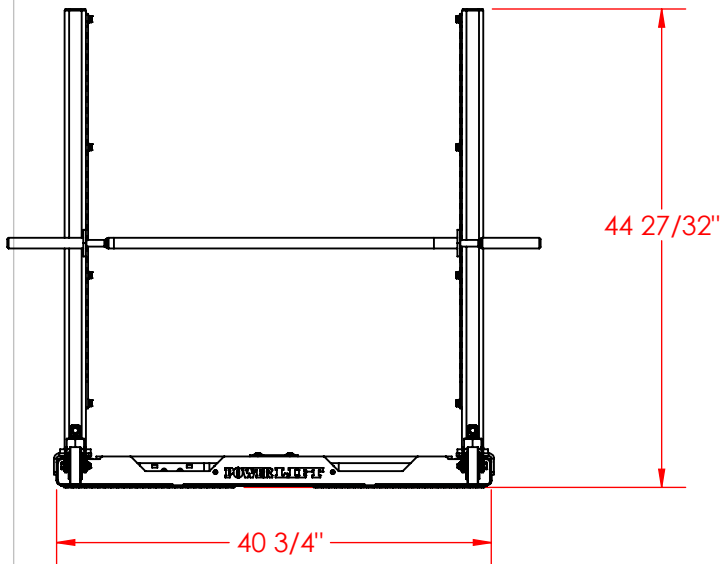
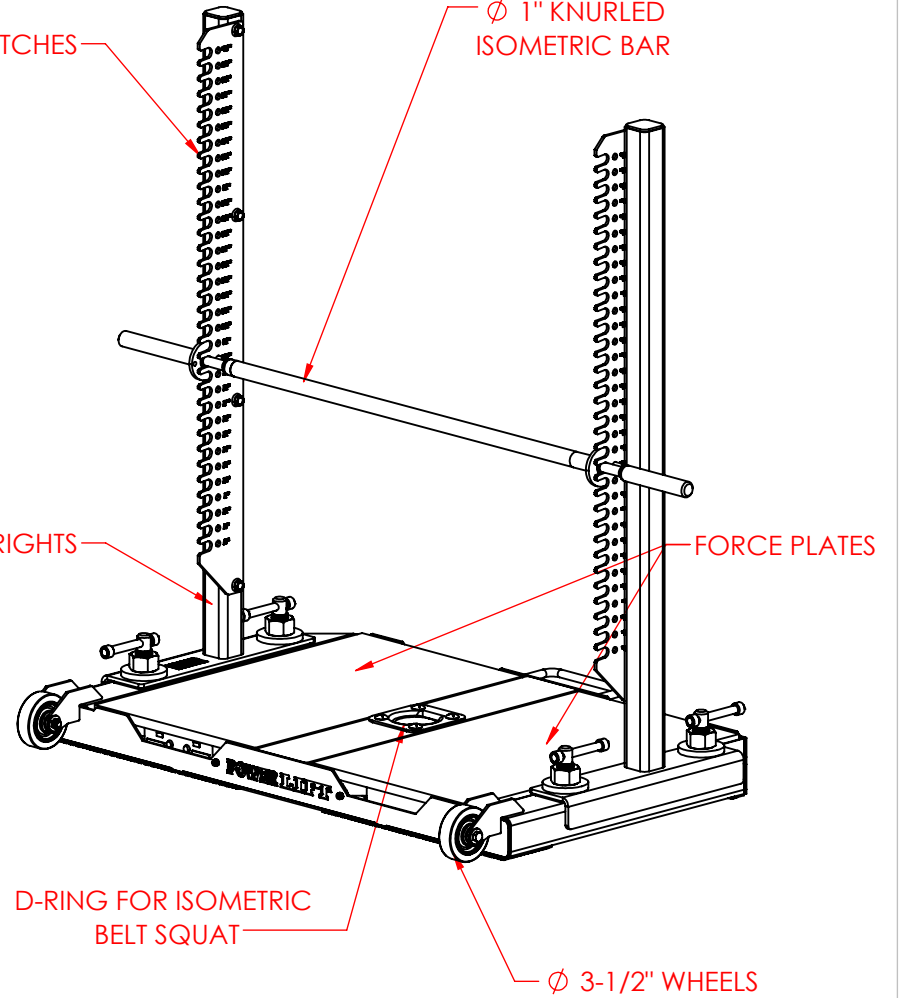

NOTE: FORCE PLATES NOT INCLUDED

UNLESS OTHERWISE SPECIFIED
DIMENSIONS ARE IN INCHES
TOLERANCES ARE:
FRACTIONS DECIMALS ANGLES
±1/16" .XX=±.02 ±1°
.XXX=±.005

REFERENCE CODE

MTP-HAWKINS

POWER LIFT®

PART NUMBER

28600A

PART NAME

ASSY, MID THIGH PULL, HAWKINS

CAD GENERATED DRAWING
DO NOT MANUALLY UPDATE.

SHEET 1 OF 2 REV. B

SCALE 1:24 SIZE A